

Better Technology Forecasting Using Systematic Innovation Methods

D. L. Mann
Systematic Innovation
Darrell.mann@systematic-innovation.com

Abstract

An evolved version of the Soviet-originated Theory of Inventive Problem Solving, TRIZ, contains a series of generically predictable technology and business evolution trends uncovered from the systematic analysis of over two million patents, academic journals and business texts. The current state of the art – recorded for the first time together in this paper – now bring the total number of generic technical trends to over 30, and the number of business trends to over 20. The paper describes some of the newly discovered trends, and their incorporation into a design method that allows individuals and businesses to first establish the relative maturity of their current systems, and then, more importantly, identify areas where 'evolutionary potential' exists. The paper introduces this concept of evolutionary potential – defined as the difference between the relative maturity of the current system, and the point where it has reached the limits of each of the evolution trends – through a number of case study examples focused on the design and evolution of complex systems.

Keywords: TRIZ, Design, Trends

1. INTRODUCTION

The Soviet inventive problem solving method, TRIZ, is built on over 1500 person years of research and the systematic study of over 2 million of the world's most successful patents [1, 2]. The method thus encapsulates the best practices of the world's best inventive minds and, by using the patent database as its source material, offers users the ability to strip away all barriers between different industry sectors. One of the key findings of the research shows that different industries have historically done a lot of wheel re-inventing, and that good ideas travel relatively slowly between different sectors.

The research has also demonstrated that there are a number of generic technology evolution trends that determine the evolution of all technical systems. These trends describe evolution towards:-

- systems with increasing benefits and decreasing cost and harm
- increased dynamization within systems
- increased system segmentation
- increased space segmentation
- increased surface segmentation
- increased controllability
- increased complexity followed by reduced complexity
- use of all available physical dimensions within a system
- decreased number of energy conversions
- increased rhythm co-ordination
- increased action co-ordination

In each case, researchers have identified a number of generic evolution steps up to and including a 'final' level of evolutionary potential. The trends and this 'evolutionary potential' concept act together as powerful guides to help determine the future development opportunities and limits for a wide variety of technical and business systems.

The paper describes an updated version of the classic TRIZ trends and the results of a series of short studies to apply them to the design of a variety of systems, starting with bearing and lubrication systems for hydraulic applications, passing through analysis of a novel synthetic material, and ending with the analysis of a hypothetical organisation system. In focusing on this broad span of applicability, the paper is able to both describe some of the uncovered trends, and to demonstrate the importance of the interactions that exist between different parts of the system. In other words, to describe how the evolution of one part of a system can and will influence the design of other parts.

In so doing, the paper also introduces a method for categorising the evolution trends into space, time and interface categories, and from there to the creation through which it becomes possible for business or technical system designers to quickly and accurately identify areas of their designs in which there is maximum potential for value generation, and, equally important, in which fundamental evolutionary limits are already being approached. The method is thus also seen as a potentially important strategic investment appraisal tool, in addition to its ability to offer unprecedented quality and quantity of knowledge on the what, how, why and when's of product and business evolution across a broad spectrum of application scenarios.

The paper begins with a section describing the concepts of ideality and evolutionary potential. The next section integrates descriptions of the generic technology evolution trends with their application to predicting the future evolution of bearing systems. This section ends with the inclusion of the evolutionary potential diagram for bearing systems. A third section then applies a larger range of the uncovered evolution trends to draw the equivalent evolutionary potential diagrams for a polyamide impact modifier material system. A fourth section examines the

business equivalent trends and evolutionary potential plotting capability and applies it to the definition of a hypothetical organisation structure. A short final section speculates on the research and intellectual property implications of the capabilities offered by the evolved TRIZ trends.

1.1 Ideality

One of the main pillars in the TRIZ philosophy is the concept of systems evolving in the direction of increasing ideality (defined as the sum of the good things in a system divided by the sum of the bad things). The concept also includes the idea of an 'ideal final result (IFR)' – defined as the evolutionary limit of a system in which all of the good things are delivered, and all of the bad things have disappeared. While this might sound somewhat fanciful on many levels, there are nevertheless many cases where such an IFR has been realised; this is particularly so when considering components within a bigger system.

The idea of a bearing system in which the user achieves the useful function of the bearing without the bearing actually existing is one of those examples where the IFR is probably some distance into the future. An important thought when comparing the exercise here with the idea of an IFR bearing involves starting with an existing system and using the trends to project its evolutionary limits, rather than adopting the usual IFR practice of starting from IFR and working backwards. Thus it will be seen that in going forwards from the known it may well become apparent that the evolutionary limits of a given design style – in the first instance 'rolling element contact bearing' – will fall short of the IFR. The overall concept is illustrated in Figure 1.

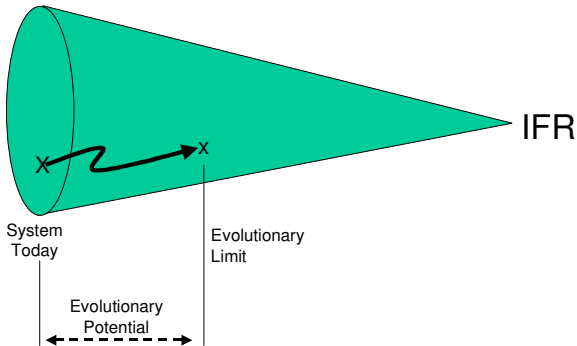

Figure 1: Ideal Final Result and 'Evolutionary Limit' Concepts.

This 'starting from today and projecting forwards' philosophy is justified on the grounds that many organisations do not have the freedom to simply shift to another – potentially very different – design philosophy.

1.2 Evolutionary Potential

Putting the IFR concept on one side, the remaining bulk of this paper looks at the exemplar hydraulic system components from the rather more pragmatic standpoint of starting from a current design, observing where it appears relative to the TRIZ predicted technology evolution trends, and consequently examining how much closer to ideality it has the ability to evolve. A component or system that has evolved all the way along each of the TRIZ trend may be said to have reached its evolutionary limit. Any unexploited evolution steps represent 'evolutionary potential' [3]. The evolutionary potential plot illustrated in

Figure 2 is used as a way of describing how far along each of the TRIZ trends a given system has evolved. Each spoke in the plot represents one of the TRIZ trends relevant to the given component. The outside perimeter of the plot represents evolutionary limit, and the shaded area represents how far along each trend the current system has evolved. Thus the area difference between shaded area and perimeter is a measure of evolutionary potential.

Where the system/component is along each trend

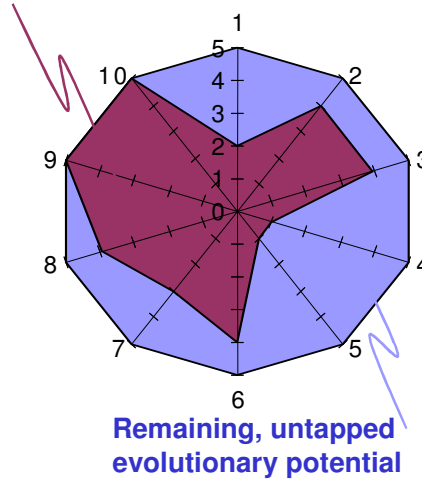

Figure 2: Evolutionary Potential Radar Plot.

The construction of an actual evolutionary potential plot is best observed through consideration of a real example. We start below with a state of the art rolling contact element bearing:

2 BEARING SYSTEM DESIGN

The start point for defining the evolutionary potential of hydraulic system bearings has been to randomly select a recent granted patent. US patent 6,296,395, granted in October 2001 to FAG in Germany has been chosen as a suitable starting point. The self-aligning bearing concept is illustrated in Figure 3 below.

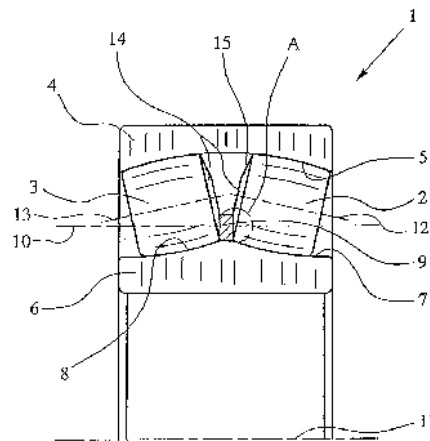

Figure 3: Exemplar State Of The Art Bearing System.

The evolutionary potential assessment task involves comparing the bearing design with each of the TRIZ trends in order to find a point along the trend that best

describes the current evolutionary state of the design. By way of example, Figure 4 describes the TRIZ trend known as 'space segmentation'. The trend shows a progression observed in other systems from solid to hollow to multi-hollow to capillary to active designs. As in all the other trends being presented, TRIZ depicts an evolutionary progression from top to bottom down each trend, in which benefits increase as a design travels further downwards.

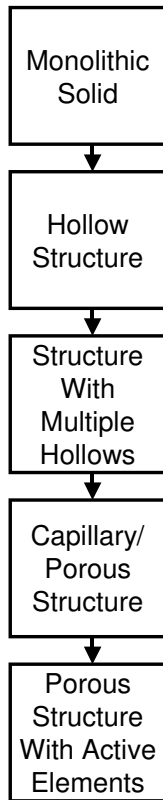

Figure 4: Space Segmentation Trend.

For the US6,296,395 design, it may thus be observed that the design uses solid roller structures. As such it has evolved along only one out of the possible five evolution stages (NB obviously the idea of hollow ball construction predicted by the trend has been achieved elsewhere and hence the equivalent evolutionary potential plot for that system would denote two out of the possible five stages of evolution). The space segmentation spoke on the radar plot the shaded area boundary for the chosen invention however will be drawn one-fifth of the way along a spoke with five graduation marks.

In terms of the current design, the task of the designer is now to work out what benefits may be accrued by tapping into the unexploited evolutionary potential. In other words, how would a hollow or multi-hollow or capillary structure offer benefits over the current hollow design? Possible examples might include increased strength/weight ratio, increased lubrication carrying capability and so on. The identification of such benefits often results in the opportunity to generate significant new intellectual property. For obvious reasons, this paper does not seek to travel in that direction.

Instead, the process of comparing the exemplar design to the TRIZ trends continues with the geometric evolution trend shown in Figure 5.

This is perhaps one of the more obvious trends; one in which benefits increase as a design exploits all of the available degrees of freedom. This is a particularly important trend in the context of many manufactured products; especially in examining the potential for evolution from the 2D to fully 3D stage, where, historically, it has been easier to manufacture things using 2D machining operations and consequently one of the available degrees of freedom has not been exploited. The increasing availability of machining capabilities where the difference in cost between 2D and 3D is zero means that the untapped benefits to be had by utilising the third dimension can be accrued without increased cost (i.e. the cost-benefit contradiction has been resolved by better manufacturing technology).

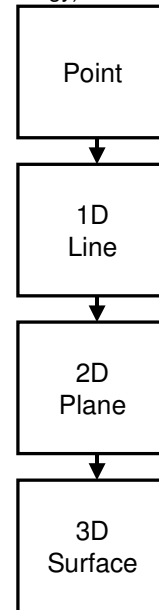

Figure 5: Geometric Evolution Trend.

In the case of the exemplar bearing, although the roller profile has taken advantage of some degree of three-dimensionality, the invention disclosure talks specifically about symmetrical designs and hence in TRIZ trend terms the third dimension has not been fully exploited. Several other areas where the third dimension has not been fully used may be seen – for example the profile of the inner and outer races, and the end planes of the bearing – and as such, the evolutionary potential plot should show that only three out of the four evolution stages have been exploited.

A close relative of the space segmentation and geometric evolution trends is the surface segmentation trend illustrated in Figure 6. This trend defines increasing benefits to be gained by evolving smooth surfaces into 2D and 3D surfaces. As with the space segmentation trend, the bearing under evaluation does not make use of any of the predicted evolutionary steps beyond the first; it thus has significant untapped surface segmentation evolutionary potential.

The controllability trend illustrated in Figure 7 is highly relevant in a bearing design context. The trend is specifically interesting here in terms of the use or otherwise of feedback in a system. It suggests the questions 'does the bearing design contain feedback, and what might the potential benefits of incorporating feedback be?' In answer to the first question, the exemplar bearing

(and most other bearing designs) do not feature any form of feedback. Possible advantages of integrating some form of feedback into the system might then include various options for monitoring the health of the bearing, for measuring loads, or for allowing optimisation of the operation of the bearing based on varying operating conditions.

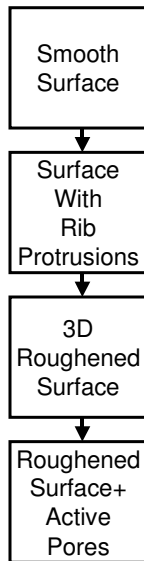

Figure 6: Surface Segmentation Trend.

While all of these potential benefits are speculative, it is clear that the 6,296,395 bearing design – like the majority of other mechanical designs has significant untapped evolutionary potential in this area. Most likely this is due to some of the difficulties and likely complexity of achieving feedback in mechanical systems (TRIZ would encourage designers to identify existing resources within the system to help deliver the required function without complicating the system). It may be observed that magnetic or other ‘field-based’ bearings do not carry such difficulties – and in fact ‘controllability’ is one of the main benefits offered by evolution to such bearing design paradigms.

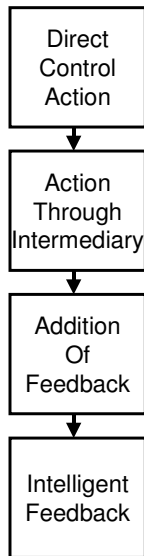

Figure 7: Controllability Trend.

Lack of space dictates the absence of the details of the evolutionary potential analysis for the other trends in the TRIZ set. Instead, Figure 8 illustrates the end result of the comparisons between the other most relevant TRIZ trends

and the 6,296,395 design. The figure thus acts as an example of the sort of analysis that can and increasingly is being conducted for other systems. For the design under evaluation, the plot clearly shows there to be considerable amounts of untapped potential in the design, and therefore that there are consequently significant improvements that we be developed.

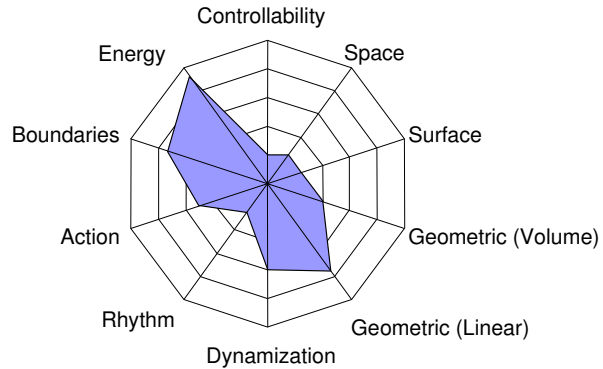

Figure 8: Bearing System Evolutionary Potential Radar Plot.

It should be noted at this point that while this plot has been drawn for the bearing as a whole, it is often the case that the analysis is conducted at the level of individual components in order to define a series of evolutionary plots. This idea is illustrated in Figure 9 – which shows how a composite radar plot from the bearing can be complemented by equivalent plots for each of the components contained in the overall assembly. Such plot families offer significant potential in terms of identifying areas to focus R&D efforts – for example there will be little point in devoting resources to developing a component with little remaining evolutionary potential when there are other components which are still at the un-evolved stages of several of the TRIZ trends.

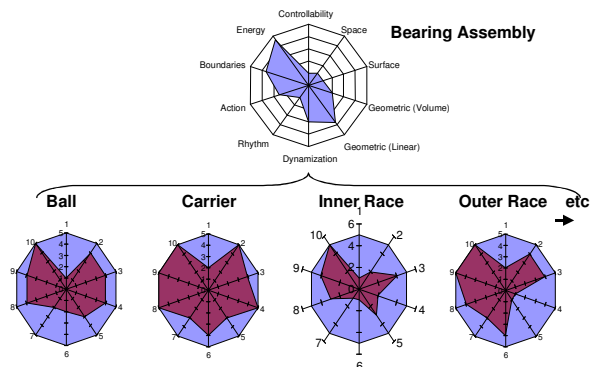

Figure 9: Interaction Between Different Trend Patterns.

This hierarchical radar plot model can of course be extrapolated to also look at the bigger system within which the bearing is just a small part.

2.1 Interaction Between Trends

One of the important characteristics to pay attention to when constructing these radar plots is the type and sequence of the trends around the plot. In line with the importance of multi-dimensional thinking within the overall TRIZ framework, it is useful to characterise the uncovered trends of evolution into three main areas – one concerned with physical and spatial characteristics; another concerned with temporal characteristics, and a third

concerning interfacial characteristics [3]. The division of the different trends into these space, time and interface categories is illustrated in Figure 10.

Descriptions of each of the trends, along with examples, may be found in [3]. For any component within a system, it is usual to make comparisons with all of the trend possibilities in order to identify the ones that are most relevant (the 'reducing energy conversions' trend, for example – which states that systems evolve in the direction of using progressively fewer energy conversions – was deemed irrelevant in this particular case because the only energy conversion associated with the bearing concerns heat generation due to inefficiencies in the system.

INTERFACE RELATED TRENDS

Mono-Bi-Poly (Similar) – Interface
 Mono-Bi-Poly (Various) – Interface
 Mono-Bi-Poly (Inc.Diff.) – Interface
 Damping
 Sense Interaction
 Colour Interaction
 Transparency
 Customer Purchase Focus
 Market Evolution
 Design Point
 Degrees of Freedom
 Boundary Breakdown – Interface
 Trimming
 Controllability
 Human Involvement
 Design Methodology
 Reducing Energy Conversions

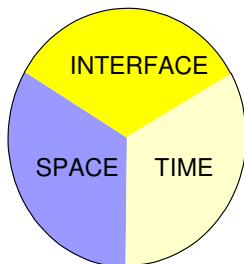

TIME RELATED TRENDS

Action Co-ordination
 Rhythm Co-ordination
 Non-Linearity
 Mono-Bi-Poly (Sim) – Time
 Mono-Bi-Poly (Var) – Time
 Macro to Nano Scale – Time

SPACE RELATED TRENDS

Smart Materials
 Space Segmentation
 Surface Segmentation
 Object Segmentation
 Macro to Nano Scale – Space
 Webs and Fibres
 Decreasing Density
 Asymmetry
 Boundary Breakdown - Space
 Geometric Evolution (Lin)
 Geometric Evolution (Vol)
 Dynamisation

Figure 10: Spectrum of Technology Trends Divided into Space, Time and Interface Categories [3].

One of the issues relating to application of the technology trends involves combination effects. There are two main situations of note in this regard; the first involves situations where evolution of a component along one trend influences evolution along another, while the second involves instances where the evolution of one component influences the evolution of other surrounding components.

An example of the first case relevant to the bearing system might involve the trend towards decreasing density in systems – which states that the materials used to construct systems will gradually evolve in a decreasing density direction. There are already bearing systems using ceramic balls, for example. A potentially novel interaction between this trend and, say, the trend towards increasing asymmetry ('systems will evolve in the direction of matching to suit external asymmetries'), which is unlikely to have emerged by examination of any of the trends on an individual basis, is to place one or two ceramic balls into an otherwise symmetrical arrangement of all steel balls. The general phenomenon with all of the trends is that benefits increase as a component or system evolves along the trend. The anticipated benefit in this instance would be that the (harder) ceramic ball 'repairs' the bearing races by rolling out any dents and holes that might form over time. Taking the asymmetry trend a little further, it might be further possible to replace more of the normal balls with ones that perform additional useful functions – e.g. (in conjunction with the controllability trend or 'colour interaction' trend) a 'marker' ball that changes colour when it wears, or a 'cleaner' ball (possibly dimpled – see surface segmentation trend) that clears foreign matter out of the path of other balls.

With respect to the second trend combination idea – that where the evolution of one component affects the evolution of another – a simple example of this in action in the bearing design might be a combination of the Geometric Evolution trend (Figure 6) applied to the shaft being supported by the bearing – for example the addition of a local conical feature – which would then influence the design of the ball bearing to take advantage of the load distribution and load control potential that such a change potentially allows.

In essence, although the concept of evolutionary potential may be seen to be relatively simple, using the mapping process outlined in Figure 9, it is possible to generate an evolution picture which quite rapidly becomes highly complex. This is in keeping with the (hopefully not surprising) knowledge that the TRIZ trends exist to provide structure to evolution thinking, and not an automatic inventing algorithm.

3 MATERIAL SYSTEM DESIGN

The evolutionary potential concept works at all of the different hierarchical levels at which a system may be observed. In the previous example, the concept was applied to a complex sub-system of a bigger system. The same ideas may be applied to that bigger system. Alternatively, as will be shown here, the concept can also be applied when a much detailed focus perspective is taken.

The exemplar system considered in this instance is US patent 4,174,358 granted to DuPont. A more comprehensive evolutionary potential radar plot for this tough thermoplastic nylon composition is presented in Figure 10. The analysis from which this plot was constructed used the relevant trends from the 35 described in [3]. This example is being used in order to first show that the number of trends detailed in the plot can vary considerably from one application to the next, despite the fact that the menu of possible trend options remains constant. Although this patent dates back to 1979, and many in the industry might state that the patent represents a significant step in bringing the industry to

maturity, the plot suggests that there is still much potential remaining in the design.

The plot is also used as an example of how the footprint described by the plot can serve to influence the future evolution direction of the DuPont patent, or any system under consideration. This can be done on several levels. Firstly, using the overall footprint it is possible to quickly identify areas where the invention is strong (points where the system is at the outer perimeter of the evolutionary potential map) and also where it is weak. Looking then at a slightly more detailed level by splitting the image into the three main space, time and interface categories, it is then possible to identify whether there is any bias between these three categories.

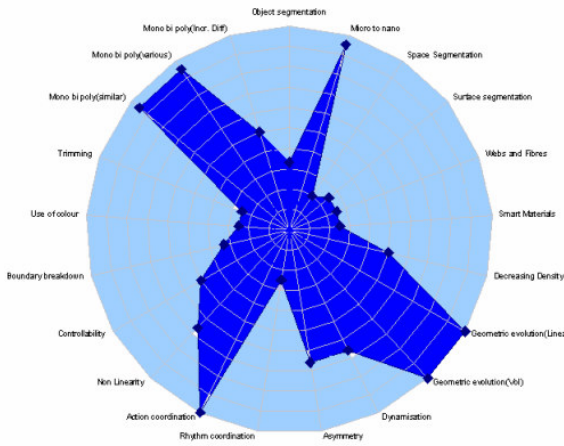

Figure 10: Evolutionary Potential Radar Plot for US4,174,358

Figure 11 shows how the invention separates into those three categories. What the plot shows in this instance is that all three have their strengths and weaknesses. For the purposes of illustrating how the plots can be used to generate ideas for improved products, the under-exploited elements of the 'interface' and 'space' evolutionary potential categories will be examined in more detail.

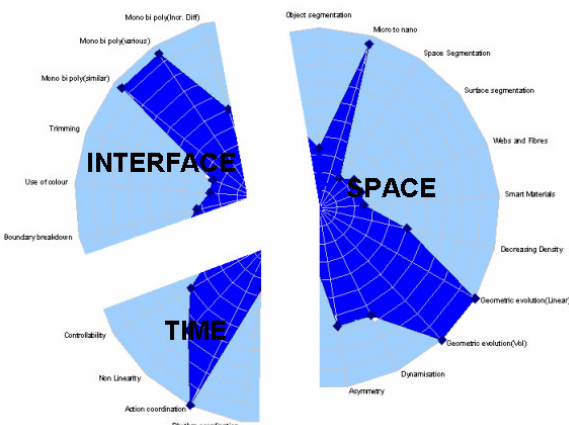

Figure 12: Space, Time and Interface Trend Split for US4,174,358

In order to examine some of the potential evolutionary improvement opportunities that might arise from utilising this under-exploited potential, some of the trend contained in this category will be examined in a little more detail.

The first of the trends that might be useful in thinking about evolving the 4,174,358 design is the 'Use of Colour' trend illustrated in Figure 12. This is a trend which has only recently emerged from the research undertaken during the preparation of [3]. The trend describes how systems evolve from not using colour as a resource (which is the case for the material system at hand – where it is usually left to the customer of the material to take responsibility for its ultimate appearance), to making binary, visible-spectrum and, ultimately, full spectrum use of colour. This trend, like the other 34 highlighted in Figure 11, can be used as a means of focusing thinking about evolving the product at hand. The questions that are supposed to be prompted by this particular trend are 'what advantages might there be in using two colours in this system?', 'what advantages are there in using all colours?'

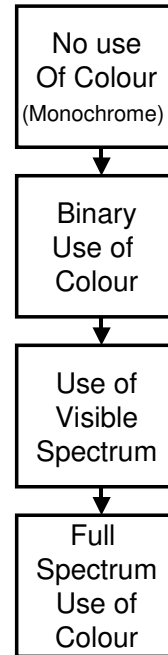

Figure 12: 'Use of Colour' Evolution Trend

At this point, the radar plot and the trends have done all that they are able, and it is up to the skills of the designer to translate these generic solution directions into things that might generate a more beneficial product. While it is clearly not the intention of this paper to generate new intellectual property, some of the possibilities suggested by the 'use of colour' evolution direction might be:-

- use of colour as a wear indicator;
- as a means of providing information about stresses in the material (colour changes with stress)
- encompassing the ability for the material to change colour due to light or temperature effects
- to provide some form of feedback signal
- active camouflage
- etc.

Basically, the possibilities are limited at this point in the process by the imagination of the user. A second example of an under-exploited trend in the existing patent comes with in the 'space' category with the 'webs and fibres' trend. This trend is illustrated in Figure 13.

Like the other possible trends, this one too can be applied at a variety of different levels – from the micro-scale (where the connections between the different molecules making up the polymer chain could be considered), at the material level (where the polymer chains making up the

material are considered), or at what TRIZ would describe as the 'super-system' level – where the interest would be in how the material interacts with the materials and components in contact with the material. In the first two of these situations, the trend is pointing in the direction of increasingly 3-dimensional polymer architectures (integration with the Mono-Bi-Poly trend would further imply 'fibres-on-fibres' for examples – like in a fractal geometry). The final 'active' trend stage suggests some of the ideas derived during the 'use of colour' trend discussion, but might also include such things as:-

- self-repairing features
- rheopectic features – enabling the stiffness of the material to vary under different load conditions
- addition of 'hooks' (possibly at the molecular level) to facilitate joining/separation of different components made of the material
- etc.

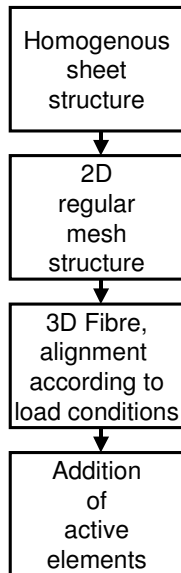

Figure 13: 'Webs and Fibres' Evolution Trend

Again, the trends are used merely to provide structure to the design evolution process. The specific solutions that may be generated by using the trends will depend on the imaginative skills of the inventive problem solver and the connections they can make between the evolution directions suggested by the trends and the benefits that may be presented to customers as a result.

4 EVOLUTIONARY POTENTIAL IN A BUSINESS CONTEXT

The evolutionary potential concept applied in a business setting is emerging as a very powerful indicator to help organisations know when systems are beginning to hit fundamental limits, and where there are opportunities to generate new improvements. This section is about applying the same techniques to business using the business trends uncovered in TRIZ for Business research [6].

In essence, the evolutionary potential concept for business works exactly the same as that for technical systems; in that the user is required to compare the current business situation with each of the known business trends in turn in order to establish a) whether the trend is relevant (note: they won't all be relevant to a given situation, but at least the question should be asked), and

b) how far along the trend the current system is. Figure 14 illustrates an example for the business variant of the 'controllability' trend previously seen in Figure 7.

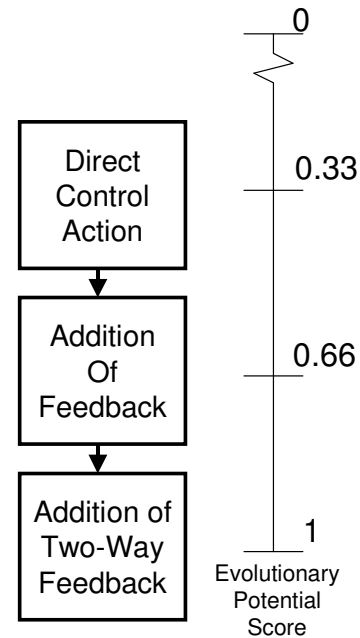

Figure 14: Business Version of Controllability Trend and Evolutionary Potential Implications

A system receives a score relative to its position along the trend, such that, for example, a system in which feedback is being used would score a 0.66.

Construction of an evolutionary potential plot for the system involves repeating this scoring process for each of the trends relevant in a business context. As with the radar plots drawn for technical systems, the evolutionary potential radar pictures offer an instant snapshot of where a system currently is and where it has unused potential to jump to higher levels of capability – as have been found by someone somewhere amongst the range of published business solutions from around the world. Figure 15 illustrates a hypothetical example. For the purpose of clarity, not all of the trends have been included.

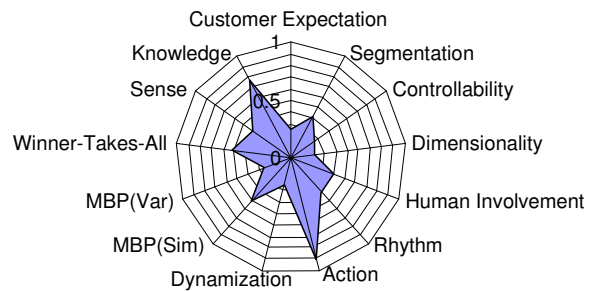

Figure 15: Evolutionary Potential Radar Plot for a Hypothetical Business System

The solid area in the plot is intended to represent the current state of the system under evaluation, while the white area to the perimeter of the plot represents potential that the system has not yet taken advantage of.

In line with the importance of space, time and interface awareness within TRIZ, Figure 16 illustrates the list of business trends thus far uncovered segmented into each of these three categories.

Some of the trends – such as ‘segmentation’ and ‘Mono-Bi-Poly’ – have relevance in each of the three categories and so are repeated for each in order to ensure that they are examined in each appropriate context. At this moment in time, 23 different trends have been uncovered, which then becomes 31 when the different interpretations in the space, time and interface categories are included.

In order to maintain a degree of consistency between different plots it is usually a good idea to maintain the sequence of the three categories when constructing the plots.

INTERFACE RELATED BUSINESS TRENDS

- Customer Expectation
- Customer Purchase Focus
- Knowledge
- Mono-Bi-Poly (Similar) – Interface
- Mono-Bi-Poly (Various) – Interface
- Mono-Bi-Poly (Inc.Diff.) – Interface
- Segmentation - Interface
- Damping
- Sense Interaction
- Transparency
- Degrees of Freedom
- Boundary Breakdown
- Trimming
- Controllability
- Human Involvement
- Winner-Takes-All

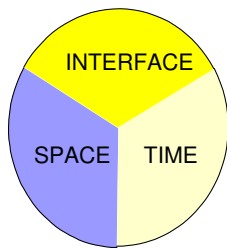

TIME RELATED BUSINESS TRENDS

- Action Co-ordination
- Rhythm Co-ordination
- Segmentation - Time
- Non-Linearity
- Mono-Bi-Poly (Sim) – Time
- Mono-Bi-Poly (Var) – Time
- Macro to Nano Scale – Time

SPACE RELATED BUSINESS TRENDS

- Mono-Bi-Poly (Similar) – Space
- Mono-Bi-Poly (Various) – Space
- Mono-Bi-Poly (Inc.Diff.) – Space
- Segmentation - Space
- Macro to Nano Scale – Space
- Asymmetry
- Geometric Evolution
- Dynamisation

Figure 16: Business Trends Divided into Space, Time and Interface Categories

Many of these trends – like the ‘controllability’ trend illustrated in its two forms in Figures 7 and 14 – have their roots in the trends originally uncovered for technical systems. Some like ‘customer expectation’ – illustrated in Figure 17 – on the other hand have their roots in the findings of more business focused researchers [7].

The main point with this and other trends, in common with the overall TRIZ philosophy, is the appropriate location and distillation of excellence in whatever form it may be found.

As with the equivalent plots for technical systems, the radar plot concept is extendable to examine different parts of a system. This is most likely to offer benefit when plots are drawn for the different sub-systems that make up an overall system – for example for departments or profit centres within an organisation. A hypothetical example is illustrated in Figure 18.

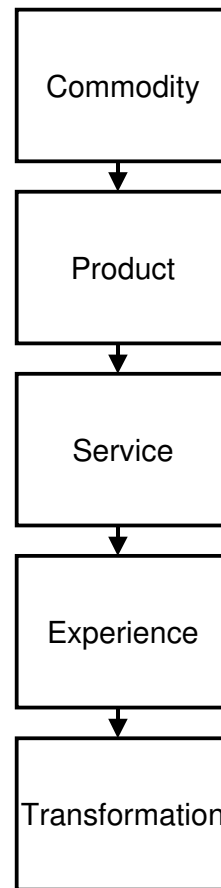

Figure 17: ‘Customer Expectation’ Trend (based on [7])

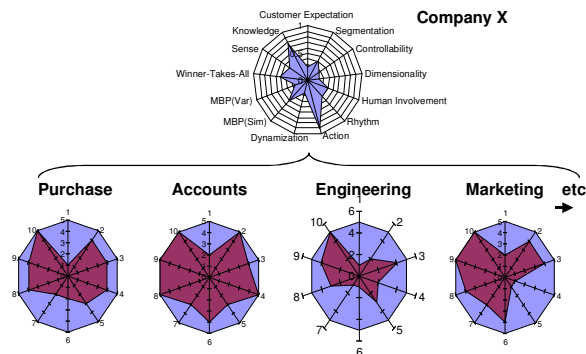

Figure 18: Hierarchical Nature of Evolutionary Potential Plots

Early experience suggests that this kind of organisational evolution snap-shot can be constructed in a relatively short period of time by a small group without prior knowledge of TRIZ or the trends.

5 CONCLUSIONS AND FUTURE IMPLICATIONS

The research conducted for this paper concludes that both of the systems considered, although perhaps thought of as ‘mature’ technologies, have considerable levels of untapped evolutionary potential remaining, and that there are consequently significant opportunities for development of both large quantities of intellectual property and improved performance benefits to customers.

The Ideal Final Result strategy contained within TRIZ, however, highlights a possible danger. Most companies are happier – and local operating constraints often dictate – working left-to-right, starting with an existing system and evolving it through ‘continuous improvement. This is fine until someone – usually someone from outside the industry based on historical analysis [5] – works out that the road to ideality is better travelled starting from IFR and working back. The evolutionary limits of an existing system may be some considerable distance away from the IFR for that system. While the evolutionary potential concept is important in terms of improving existing products, it is no substitute for an IFR start position in the large majority of instances.

TRIZ also shows that sub-systems and components like bearings, materials, etc often achieve ideality (i.e. delivering the function without the system existing) by having something else higher up the overall system hierarchy perform the function. This is usually the direction from which the main threat to a sub-system comes. Organisations need to obtain a much more holistic view of the places of their products, processes and services in the bigger scheme of things if they are to have a chance of countering the threats from other, higher level systems.

The ‘evolutionary potential’ concept, meanwhile, appears to offer benefits to users in terms of offering better understanding of how well a system is evolved, where to

focus future R&D efforts (there being little advantage, for example, in devoting resources to improvement of aspects that are already at their evolutionary limits), and how close to ideality it will ultimately be able to evolve.

The next part of the process involve understanding innovation timing – answering the ‘when?’ questions. This is a subject discussed in more detail in [3], and to be discussed in future case study examples.

6 REFERENCES

- [1] Altshuller, G.S., 1984, ‘Creativity As An Exact Science’, Gordon & Breach, New York.
- [2] Salamatov, Y., 1999, ‘TRIZ: The Right Solution At The Right Time’, Insytec BV, The Netherlands.
- [3] Mann, D.L., 2002, ‘Hands-on Systematic Innovation’, CREAX Press.
- [4] Mann, D.L., 2000, ‘Design Without Compromise: Design For Life’, paper presented at International Fluid Power Exhibition, Chicago.
- [5] Utterback, J., 1995, ‘Mastering The Dynamics of Evolution’, Harvard Business School Press.
- [6] CreaTRIZ for Managers and Business, Version 3.0, www.creax.com, 2001.
- [7] Pine, B. J., 1999, ‘The Experience Economy’, Harvard Business School Press.